

# ELWA

## Use solar power directly for domestic water heating

ELWA is a 2 kW photovoltaic water heating device. Direct current from photovoltaic modules is transferred directly to the built-in heating element and immediately converted into heat without loss.



- 100 % PV self-consumption
- Easy installation
- AC backup heating included
- No need for grid connection permits
- Lower cost compared to conventional hot water systems
- 2 ELWAs allow stratification-heating
- Low maintenance costs

## How ELWA works

ELWA uses DC power from PV panels directly for water heating. No grid connection, no inverter, and no need for grid connection permits. Very easy to install. The patented ELWA system provides up to 50 % of the annual hot water demand of a four persons household.

With a DC power of 2,5 kWp ELWA replaces a four to ten square meter solar thermal system. Automatic AC back-up heating ensures hot water supply during rainy days.

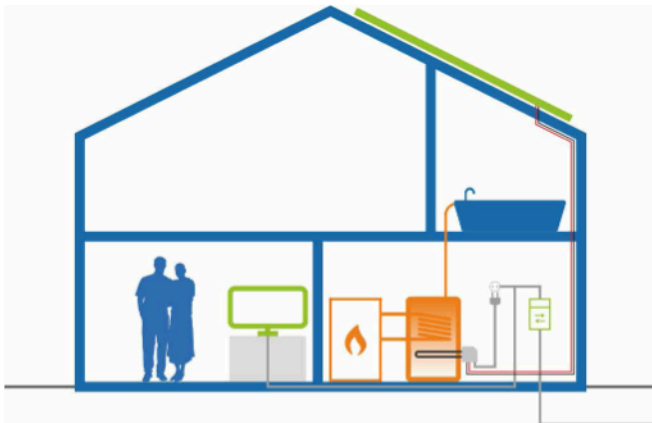

### Areas of application

#### ELWA in single-family home

ELWA perfectly fits to hot water tanks from 100 up to 1000 liters.

And: it works without any mains power, even during blackouts. Only 2 watts solar power is required to run the system - it provides hot water even under low irradiation conditions.

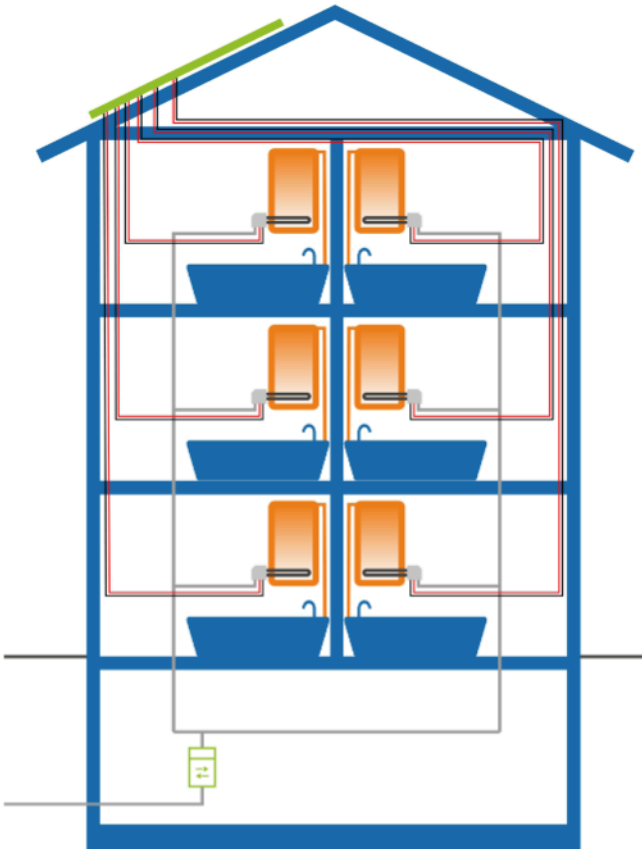

#### ELWA in commercial building

Grid connected system installation may be complicated in commercial buildings. ELWA is the perfect solution to supply each apartment separately with solar energy. It works even during bad weather conditions.

## Standard installation

Place ELWA at the lower part of the hot water tank to use the maximum water volume as storage. The electrically isolated heating rod fits to most standard hot water tanks. ELWA can be mounted to G 1 1/2 inch fittings for immersion heaters or with an adapter plate to the inspection flange.

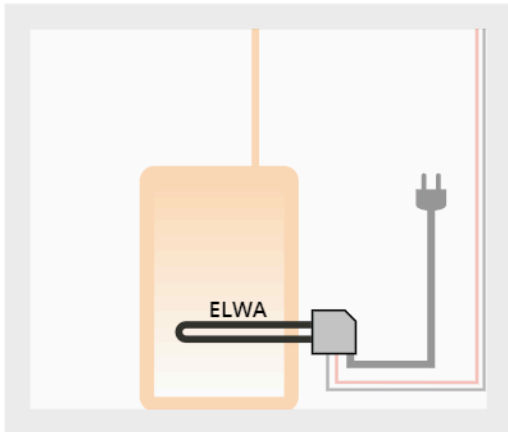

## Stratification heating

ELWA can be used for stratification heating if a second unit is installed. One unit is mounted at the upper part of the hot water tank, the second at the bottom.

Advantage: hot water is provided much faster.

Communication works via DC cables - no extra wiring!

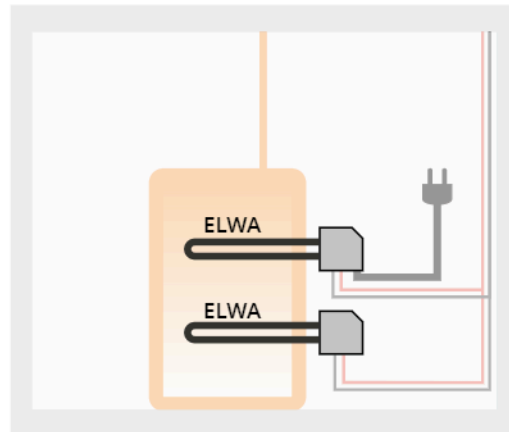

## Advantages compared to solar thermal systems

- Simple installation: only two DC cables are needed, no water pipes
- Almost no losses between PV-modules und hot water tank
- Low maintenance: no moving parts, no glycol
- PV modules offer more energy yield at low outside temperatures
- No stagnation problems, starts automatically if hot water temperature is below limit

## How large should the photovoltaic system be?

For 50 % solar coverage you need a hot water consumption of 50 L/day and person.

The technical system design is similar to that of inverters. Our excel tool helps you with your PV-system-dimensioning.

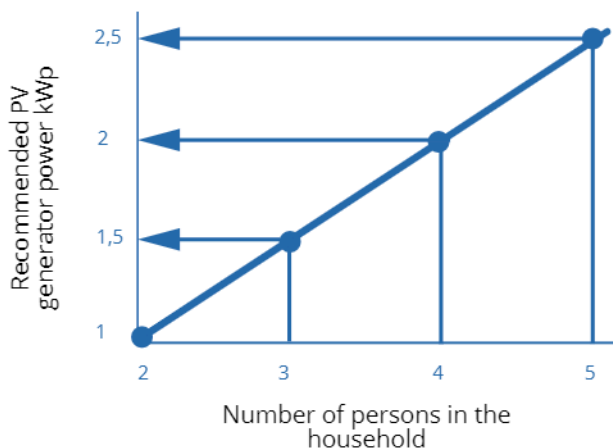

Input fields		v170227 PV array dimensioning for my-PV ELWA		MYPV	
<b>Panel characteristics</b>					
270	[Wp]	Pmpp / nominal power			
8,73	[A]	Impp / nominal current			
38,40	[V]	Voc / open circuit voltage			
30,90	[V]	Vmpp / nominal voltage			
-0,320	[W/C]	Temp. coefficient of Voc (negative value)			
	[%/C]				
<b>Array characteristics</b>					
4	[pcs]	Number of panels in series			
1	[pcs]	Number of strings parallel			
-15	[°C]	lowest panel temperature during the year			
60	[°C]	highest panel temperature during the year			
<b>Results</b>					
<b>Results for STC (standard test conditions)</b>					
1080,00	[Wp]	installed nominal power			
		OK			
8,73	[A]	total current at STC (standard test conditions)			
		OK			
153,60	[V]	total open circuit voltage at STC (standard test conditions)			

Excel-Tool:



## Technical Data

### DC Operation

DC voltage = MPP voltage range	100 – 360 V (max)
Number of MPP trackers	1
Max. input current	10 A, limited
DC nominal power	2.000 W at 25° C ambient temperature, built-in derating
DC inputs	MC4, 1 string

### AC Operation

Heating power	750 W
Mains supply	single phase, 230 V, 50 – 60 Hz
Fuse	10 A min.
Power cord	3 m
Standby-consumption	0 W at DC operation, <2 W at AC operation

### General data

MPP-efficiency	99.9 %
Total efficiency	>99 % at nominal power
Protection class	IP20
Operating temperature range	10 °C to 40 °C
Display	3 LED's
Interface	Serial IR Interface
Dimensions (lxhxd)	130 x 190 x 600 mm including heating rod
Weight	2 kg
Heating rod length	45 cm
Heating rod thread dimension	G 1 1/2 inch
Certification	CE
Warranty	2 years
my-PV article number	12-0100

### Accessories

USB Interface	ELWA software available at <a href="http://www.my-pv.com">www.my-pv.com</a>
ELWA Modbus Interface	For real time system monitoring, further temperature sensor included.

