



# **INSTALLATION, OPERATION & MAINTENANCE MANUAL OF**

BW-Backup Box Pro  
R1.0

## **DISCLAIMER**

Copyright © 2025 by the manufacturer. All rights reserved.

No part of this document may be reproduced or transmitted in any form or by any means with- out prior written consent of manufacturer.

The material furnished in this document is believed to be accurate and reliable. The information and recommendations in this document do not constitute commitments or warranties in the form of assignments. The information in this document is subject to change without notice. You may refer to the manufacturer Cloud Platform for the most updated version.

All company and brand products and service names are trademarks or registered trademarks of their respective holders.

## **COPYRIGHT STATEMENT**

This manual is under the copyright of manufacturer. with all rights reserved. Please keep the manual properly and operate in strict accordance with all safety and operating instructions in this manual. Please do not operate the product before reading through the manual.

# TABLE OF CONTENTS

<b>01</b>	<b>Introduction</b>	<b>01</b>
	1.1 Product functions.....	01
	1.2 Appearance of the product.....	01
	1.2.1 Dimensions.....	01
	1.2.2 Port view.....	02
	1.2.3 Internal diagram.....	02
	1.3 Symbols explanation.....	03
<b>02</b>	<b>Safety</b>	<b>05</b>
	1.4 Safety instructions for backup-box.....	05
	1.5 Important safety instructions.....	05
<b>03</b>	<b>System Wiring Diagram</b>	<b>06</b>
<b>04</b>	<b>Install Wiring</b>	<b>07</b>
	4.1 Installation Space Requirements.....	07
	4.2 Installation .....	07
<b>05</b>	<b>Configuration</b>	<b>11</b>
	5.1 Configuration on Haier energy APP.....	12
	5.2 Configuration on Haier energy Web .....	13
<b>06</b>	<b>Specification</b>	<b>14</b>
<b>07</b>	<b>Routine Maintenance</b>	<b>15</b>
<b>08</b>	<b>System Wiring with Meter</b>	<b>16</b>
<b>09</b>	<b>Manufacturer</b>	<b>18</b>

### 1.1. Product functions

**Meter Function:** This device integrates the functions of the PV Meter and Grid Meter.

**Whole-House Backup Power Function:** This device monitors grid status in real time. In case of grid loss or abnormalities, it rapidly switches to backup power mode to supply electricity to all household loads.

**Load Management:** Based on the customer's SOC (State of Charge) settings, it controls the power supply priority of loads, ensuring that critical loads receive power first.

### 1.2. Appearance of the product

#### 1.2.1. Dimensions (mm)

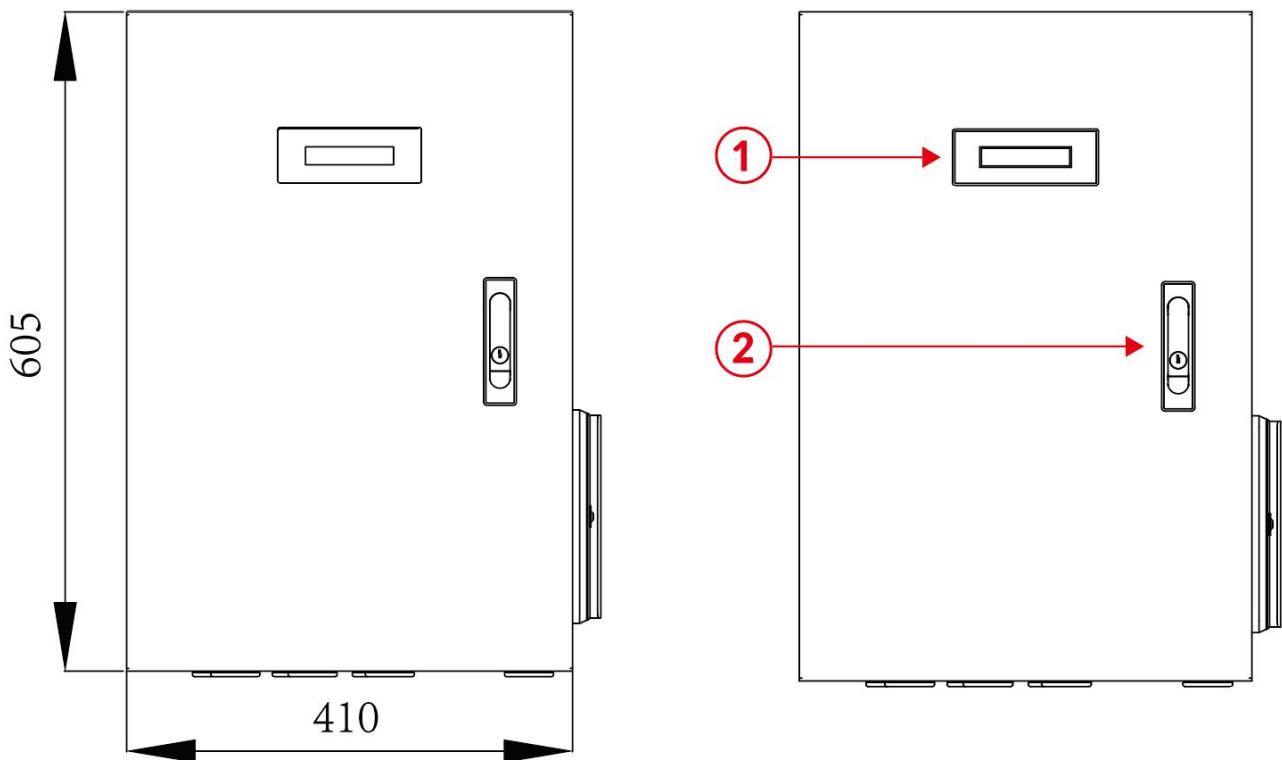

#### ① LCD Screen

First line: Model,

Second line: Version number, three phase, and N: Relay not delayed closing,  
D : Grid connected relay delayed closing for 5 minutes.

M1 L2: L2 phase voltage on the grid side current

+ - : Absorb and consume power from the power grid apparent power

Ein2 : Energy consumption of L2 phase in the power grid

RY1OFF: Power grid relay status

Eout Backup : consume energy

RY2OFF BackUP: state

Tmax: maximum temperature

#### ② Lock

### 1.2.2. Port view (mm)

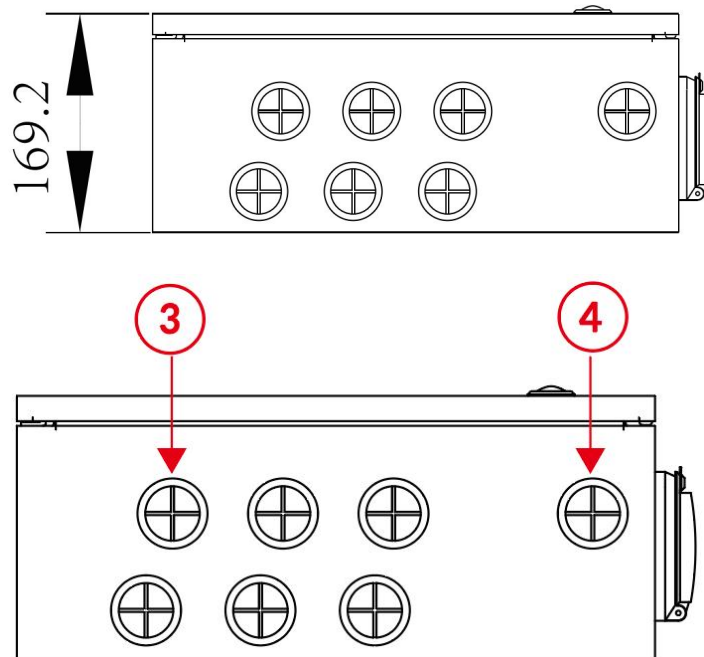

③ Power Connection Port

④ Communication Port

### 1.2.3. Internal diagram

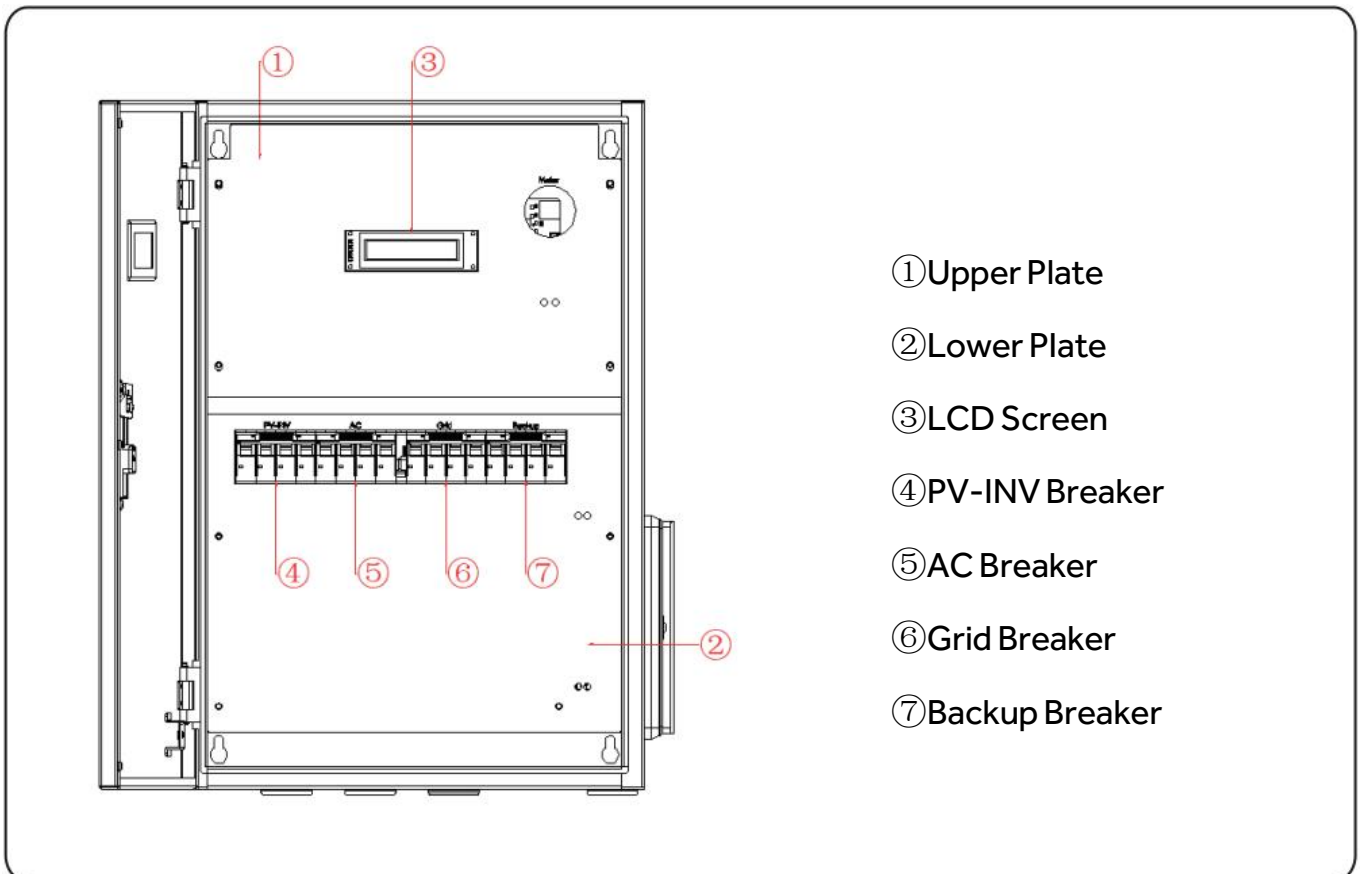

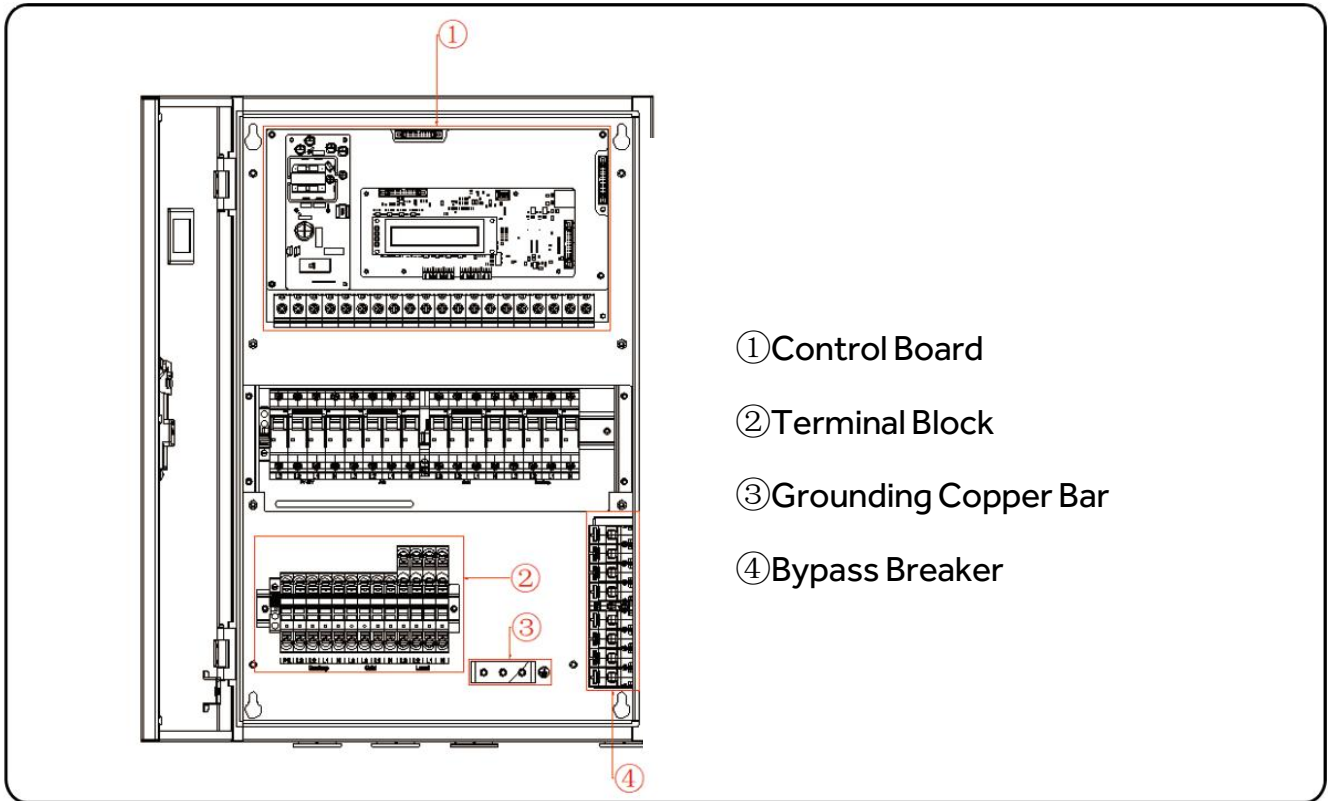

**Note:**

- All electrical appliances in the homeowner's residence can be connected as smart loads.  
 The total whole house load should not exceed rate power of inverter.
- To maximize the product's benefits for users, high-power devices (e.g., heat pumps, pool heaters, dryers, or instant heaters) are recommended for smart load connection, which can be disconnected when energy storage capacity is insufficient. Low-power devices (e.g., lights, routers) can be connected as household loads.

**1.3. Symbols explanation**



Beware of hot surface  
The product can get hot during operation.



Danger to life due to high voltages in the inverter, observe a waiting time of 5 minutes. Prior to performing any work on the inverter, disconnect it from all voltage sources as described in this document.



Beware of electrical voltage  
The product operates at high voltages.



Observe the documentation.



Grounding Mark



RoHS labeling  
The product complies with the requirements of the applicable EU directives.



CE marking  
The product complies with the requirements of the applicable EU directives.

---

### 2.1. Safety instructions for backup box

- Over voltage or wrong wiring can damage the backup box and cause deflagration, which can be extremely dangerous.
- Backup-box is not user-serviceable. There is high voltage in the device.
- Read the label with Warning Symbols and Precautions, which is on the right side of the backup box
- Do not damage the backup-box in such ways as dropping, deforming, impacting, cutting or penetrating with a sharp object. It may cause a leakage of electrolyte or fire.
- Do not expose backup box to open flame.

### 2.2. Important safety instructions

**⚠ DANGER** Danger to life due to electric shock when live components or cables are touched.

There is high voltage in the conductive components or cables of the product. Touching live parts and cables can result in death or lethal injuries due to electric shock.

- Do not touch non-insulated parts or cables.
- Disconnect the product from voltage sources and make sure it cannot be reconnected before working on the backup-box.
- After disconnection, wait for 5 minutes until the capacitors have discharged.
- Do not open the product.
- Wear suitable personal protective equipment for all operations on the product.

# 03 SYSTEM WIRING DIAGRAM

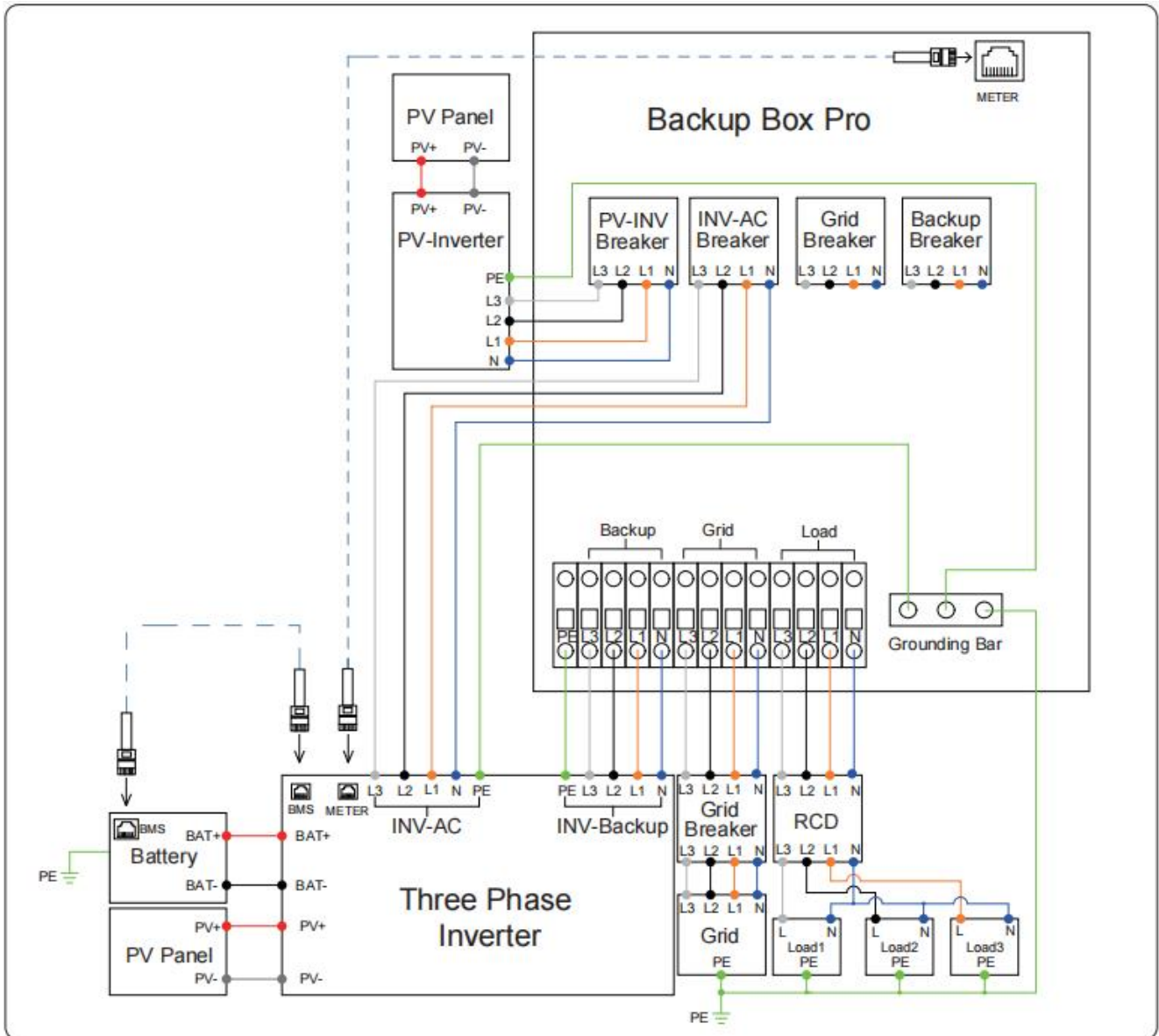

## 4.1. Installation Space Requirements

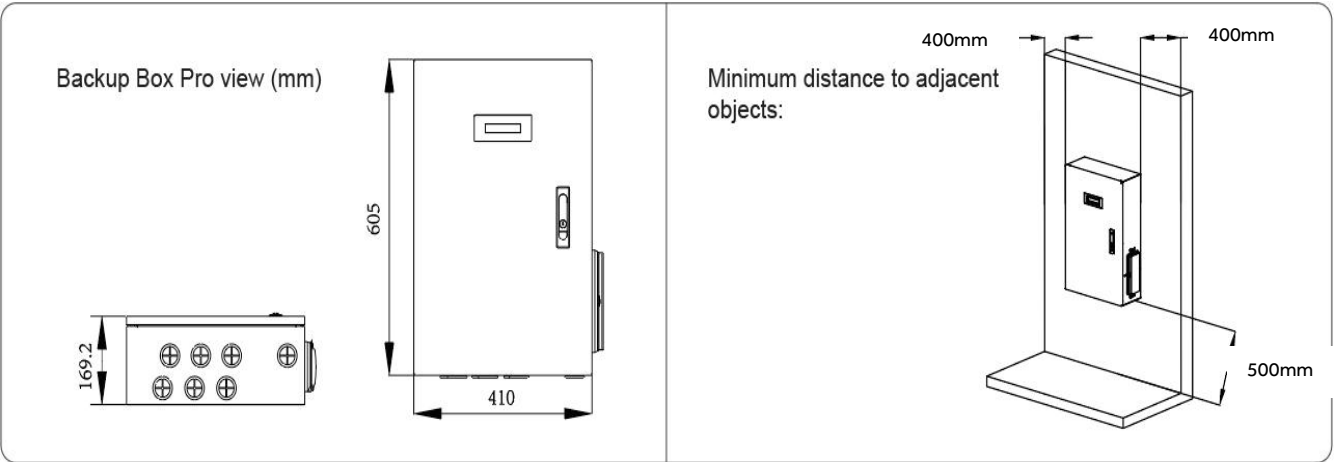

## 4.2. Installation

### Step 1

Take out the Backup Box Pro and accessories from the package.

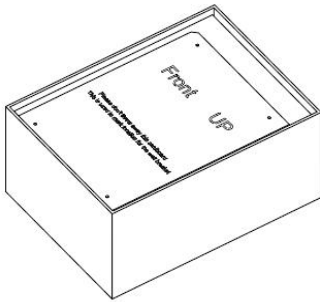

#### NOTE

Please pay attention that the quantity of accessories is consistent with the details on the manual.

### Step 2

Place the cardboard on the wall where the Backup Box Pro will be installed, and mark on the wall according to holes on the cardboard.

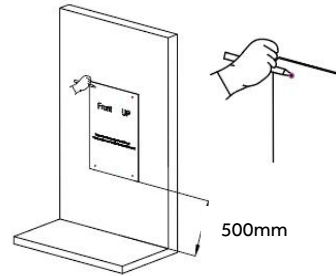

#### NOTE

Please ensure that the cardboard is level to prevent the Backup Box Pro from tilting after installation.

### Step 3

Use the impact drill to drill holes according to the marks on the wall (Drill: M10, Depth: 70mm).

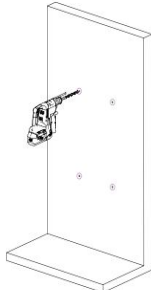

### Step 4

Take out the plastic expansion screws and vertically place the expansion tubes into the holes.

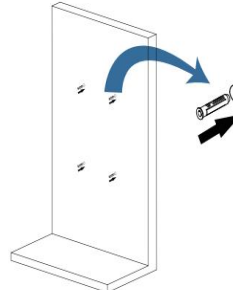

#### NOTE

The expansion tube should be completely buried in the hole and should not protrude from the wall.

### Step 5

Lock the expansion screws into the two upper holes.

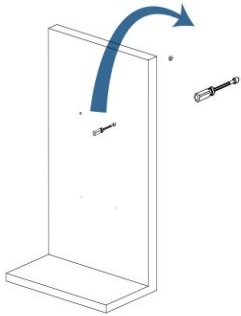

#### NOTE

Reserve a distance of 3-8mm between the bottom of the expansion screw and the wall to facilitate subsequent installation.

### Step 6

Hang the Backup Box Pro on the installed expansion bolt.

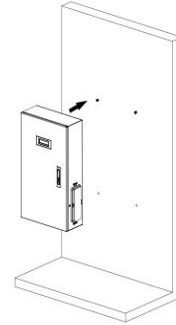

### Step 7

Use the key to open the cover, and use the SW10 sleeve to lock the two expansion screws above.



#### NOTE

The tool used in this step should be matched with the extension rod (about 200mm).

### Step 8

Lock the two expansion screws at the bottom.

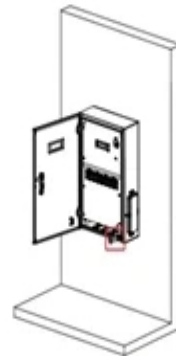

### Step 9

Use a T20 screwdriver to remove the insulation plate.

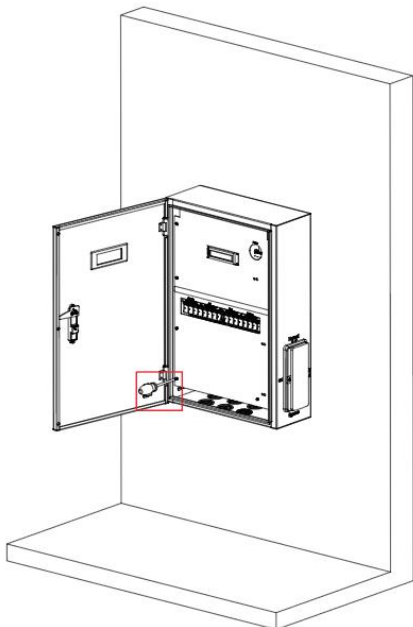

### Step 10

Connect the backup cables.

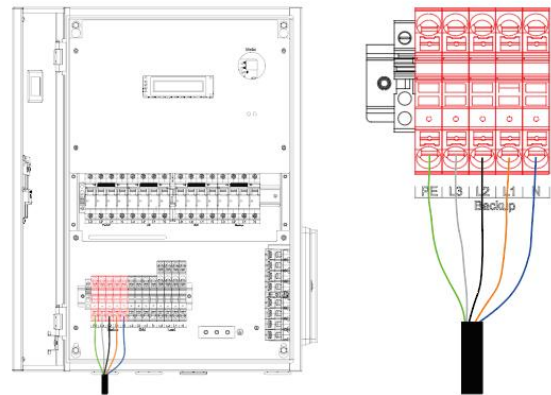

#### NOTE

When connecting cables, the cable must pass through the rubber plug at the bottom. The rubber plug should be cut with a knife along the middle cross.

### Step 11

Connect the grid cables.

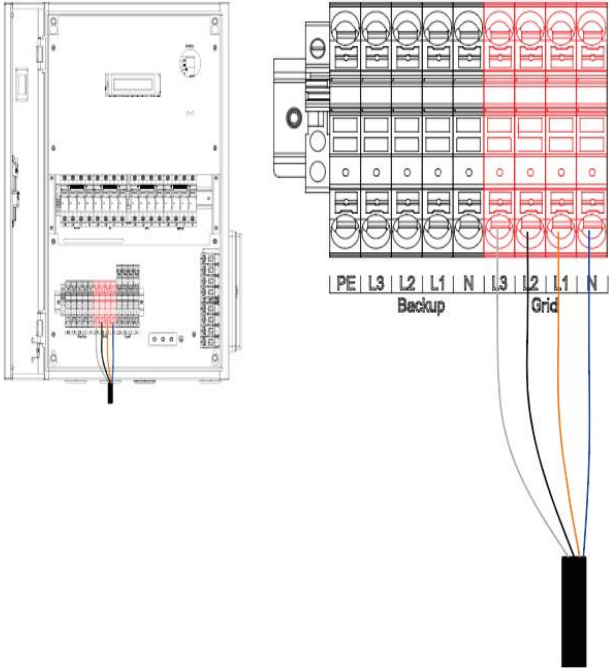

### Step 12

Connect the Load cables.

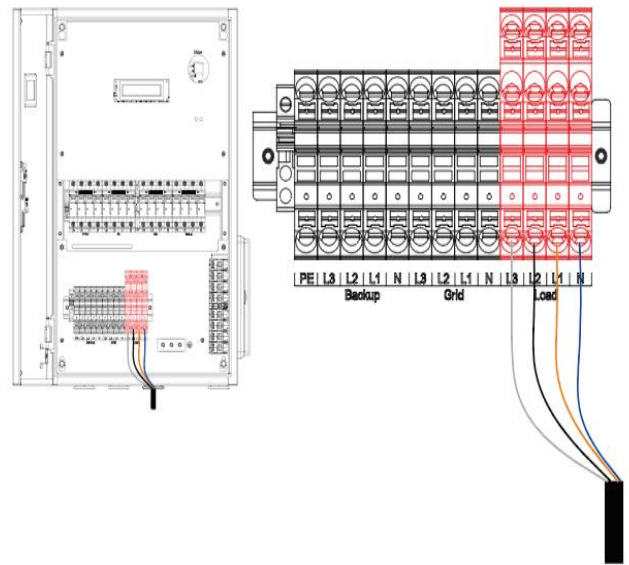

### Step 13

Connect the PV-INV cables.

Tool: #2 screw torque: 2Nm

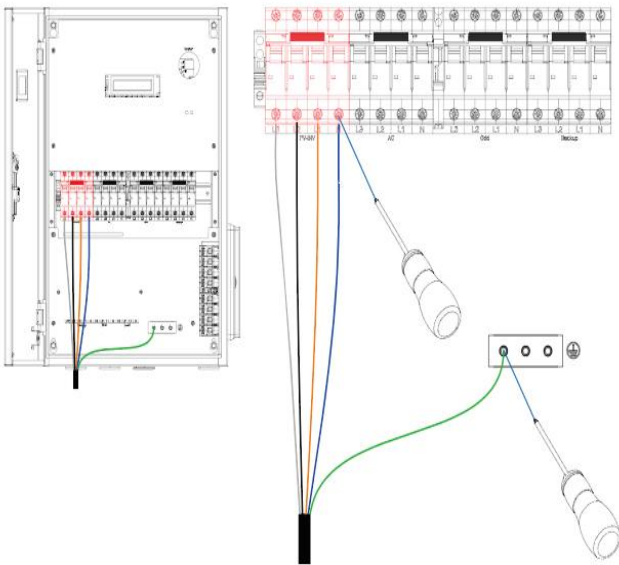

### Step 14

Connect the AC cables.

Tool: #2 screw torque: 2Nm

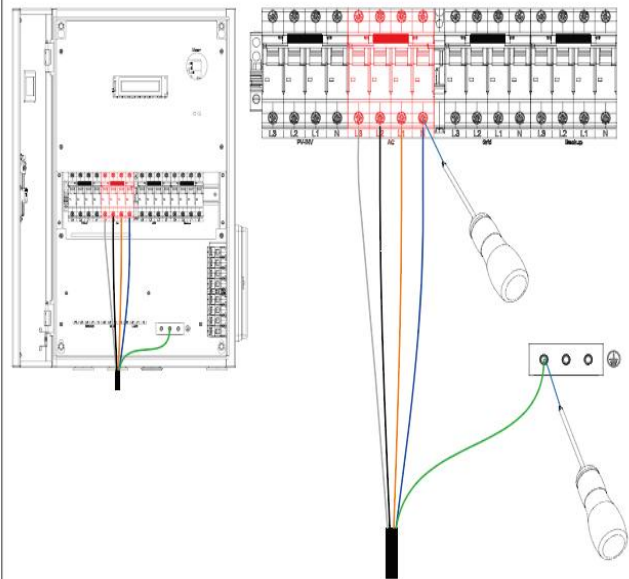

### Step 15

Install the insulation plate removed in step 9.



### Step 16

Connect the communication cable.

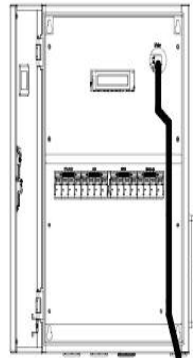

To EMS Meter Port

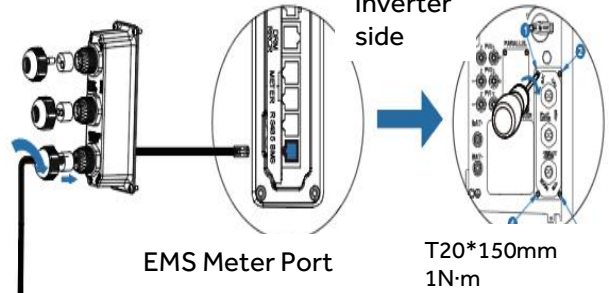

#### NOTE

The communication cable must be passed through the cable tie which is installed on the insulation plate. Then, secure the cable tie.

### Step 17

DIP Switch Configuration

DIP Switch	Description
1	Dial to "OFF" for three-phase system and "ON" for single-phase system.
2	Undefined
3	Undefined
4	Dial to "ON" for power recovery delay and "OFF" to turn off power recovery delay.

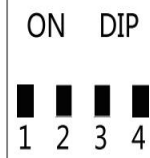

### Step 18

After the system starts up, switch the 'Normal' circuit breaker to the 'ON' position. Note: After the 'Bypass' circuit breaker switch to the 'ON' position, the load power supply comes entirely from the power grid.

#### NOTE

Please keep the key properly.

Before configure Backup Box Pro, determine the installation scenario based on the electricity meter accessories:

1. If no electricity meter is selected, proceed with installation according to Scenario 1.
2. If an electricity meter 100A/40mA/6CT is selected, proceed with installation according to Scenario 2.

Scenario 1: Please configure the electricity meter as Please install in accordance with the wiring diagram 'System Wiring Diagram with Backup Box Pro', page 16.

Application Scenario	Option
The user did not connect other inverters.	Grid Smart Meter (No CT)
The user needs to connect other inverters through smart meter without CT.	Grid Smart Meter (No CT)+Smart Meter (No CT) for 3 <sup>rd</sup> -Party Inverter
The user needs to connect other inverters through smart meter with CT.	Grid Smart Meter (No CT)+Smart Meter (CT) for 3 <sup>rd</sup> -Party Inverter

Scenario 2: Please configure the electricity meter as follows: Please install in accordance with the wiring diagram 'System Wiring Diagram with Backup Box Pro (Heavy Load)', page 17.

Application Scenario	Option
The user did not connect other inverters.	Grid Smart Meter (With CT)
The user needs to connect other inverters through smart meter without CT.	Grid Smart Meter (CT)+Smart Meter (No CT) for 3 <sup>rd</sup> -Party Inverter
The user needs to connect other inverters through smart meter with CT.	Grid Smart Meter (CT)+Smart Meter (CT) for 3 <sup>rd</sup> -Party Inverter

## 5.1 Option1: Configuration on Haier energy APP

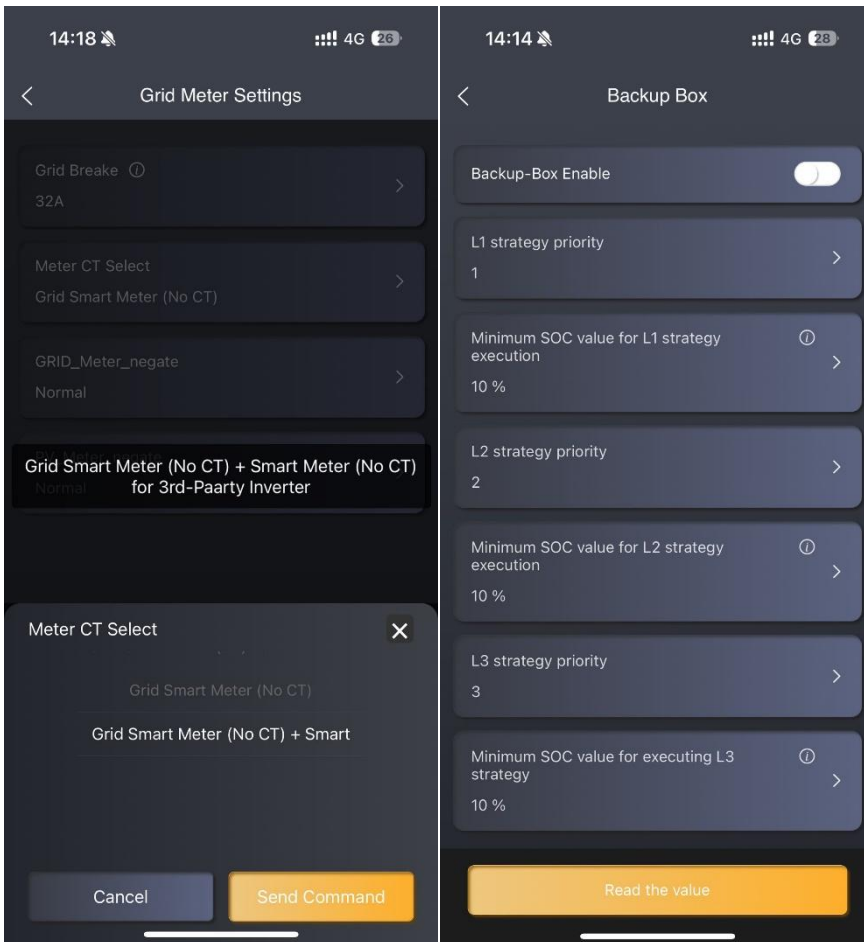

**Step1 :** Log in Haier energy APP , according to Scenario 1 or Scenario 2 , do Meter settings

**Step2 :** Select "Enable Backup Box" and set different priorities and minimum SOC values for each phase , then save.

## 5.2 Option2: Configuration on Haier energy Web

Step1: Log in to <https://hemseu.haier-energy.com>, and input the inverter SN to check the status of your system.

SN	MES SN	Device Name	Installer
1 MB02T8D0000LHRAW0004	MB02T8D0000LHRAW0004	Inverter0004	Koerts Projects

Step2 : According to Scenario 1 or Scenario 2 , do Meter settings

Meter Settings

Grid-Side Power Consumption Limit 40A Save

Meter/CT Installation Option Grid Smart Meter (No CT) Save

PV Meter Reverse Connection Flag Normal Save

Multiple Read

Step3 : Select "Enable Backup Box" and set different priorities and minimum SOC values for each phase , then save.

Backup Box

Enable Backup-Box Save

L1 Strategy Priority 1 Save

SOC Value for L1 Power Cut 10.0 % Save

L2 Strategy Priority 2 Save

SOC Value for L2 Power Cut 10.0 % Save

L3 Strategy Priority 3 Save

SOC Value for L3 Power Cut 10.0 % Save

Multiple Read



## 06 SPECIFICATION

Model	BW Backup Box Pro
Phase	Three Phase
Communication	RS-485
Display	LCD
Operating Temperature	-10℃ -50℃
Relative Humidity	0%-85 %
IP Protection	IP21
Dimension (W x D x H)	410 x 169 x 605 mm
Warranty	5 Years
Nominal Backup Power	20kW (Maximum support)
Grid Voltage Range	380/400V (3L/N/PE)
Grid Frequency	50 Hz
Max. Grid Current	63 A
Max. Backup Current	30 A
Circuit Current	1*PV inverter breaker-63A 1* AC breaker -32A 1*Grid breaker -63A 1*Backup breaker-32A 1*Normal switch-63A 1*Bypass switch-63A
Net Weight	25 kg
Switch time	38ms
Certification Standards	REACH, IEC61439-5, EN IEC 61000-6-4:2019, EN IEC 61000-6-2:2019, EN IEC 61000-6-4:2019, EN IEC 61000-6-2:2019

## 07 ROUTINE MAINTENANCE

To ensure long-term optimal performance of the equipment, routine maintenance as described in this chapter is recommended.

**⚠ DANGER**

If you need to remove the protective cover plate, please have it assessed by a professional before proceeding.

Scope of examination	Check method	Shut down	Regular maintenance
System cleaning	Check the equipment regularly for obstructions or dust. If found, clean it. Do not use tools that may cause electric shock or insulation damage, such as wire brushes.	YES	Every 3 months
System status	<ul style="list-style-type: none"> <li>• Check if the device looks damaged or deformed.</li> <li>• Listen for any abnormal sounds during operation.</li> <li>• Check if all parameters are correctly set while the device is running.</li> </ul>	NO	Once every 6 months
Electrical connection	<ul style="list-style-type: none"> <li>• Check if the cable terminal connections are loose.</li> <li>• Check if the cable surface is damaged.</li> <li>• Check if the cable's metal-contact surface has scratches.</li> <li>• Check if unused routing holes are sealed.</li> </ul>	YES	After the start of the treatment, the checkup should be done once every 6 months, and then every 6 to 12 months.
Ground reliability	Check if the grounding cable is intact and securely connected.	NO	After the start of the treatment, the checkup should be done once every 6 months, and then every 6 to 12 months.



# 08 System Wiring Diagram

## 1. System Wiring Diagram with Backup Box Pro

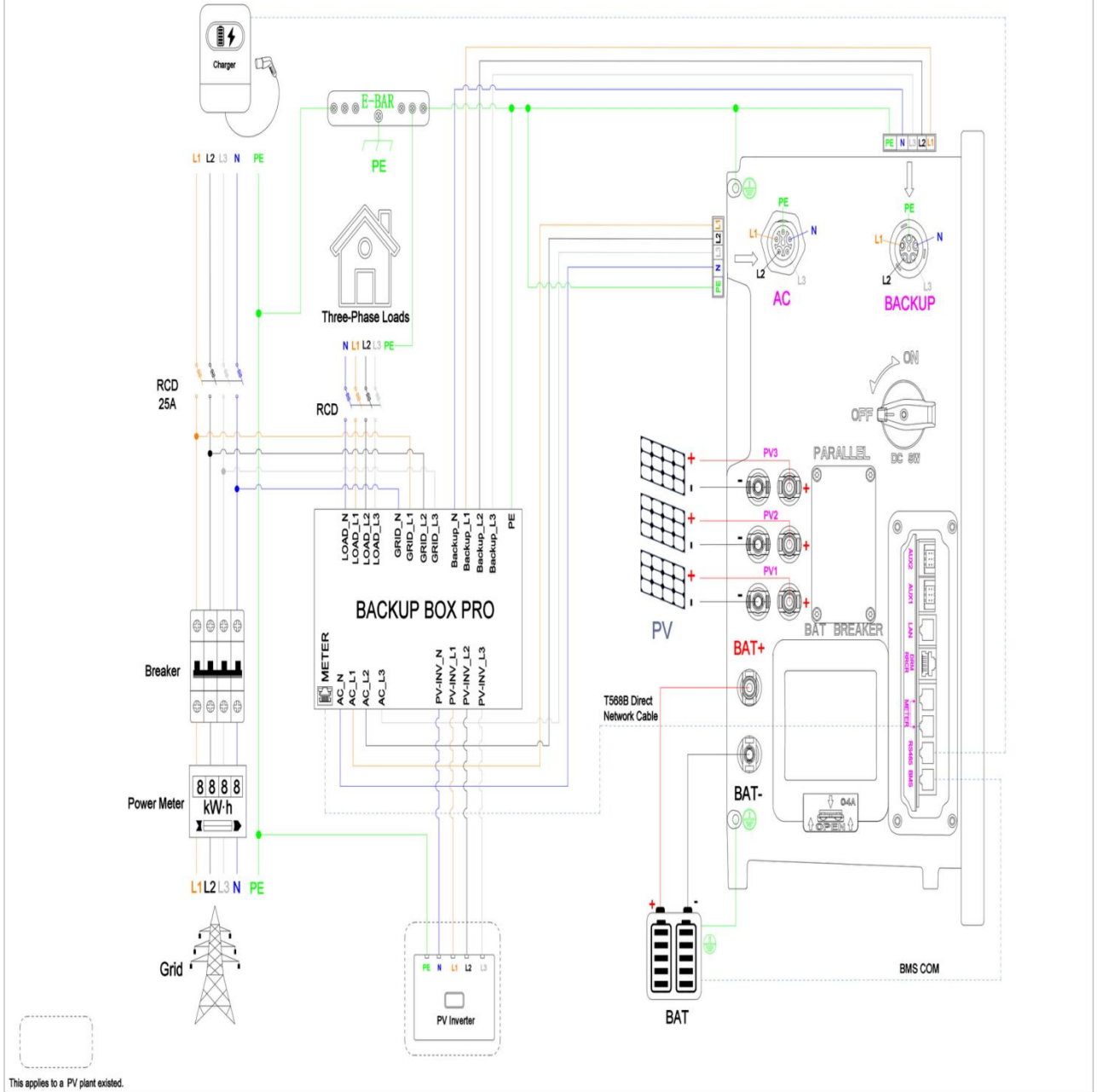

## 2. System Wiring Diagram with Backup Box Pro (Heavy Load)

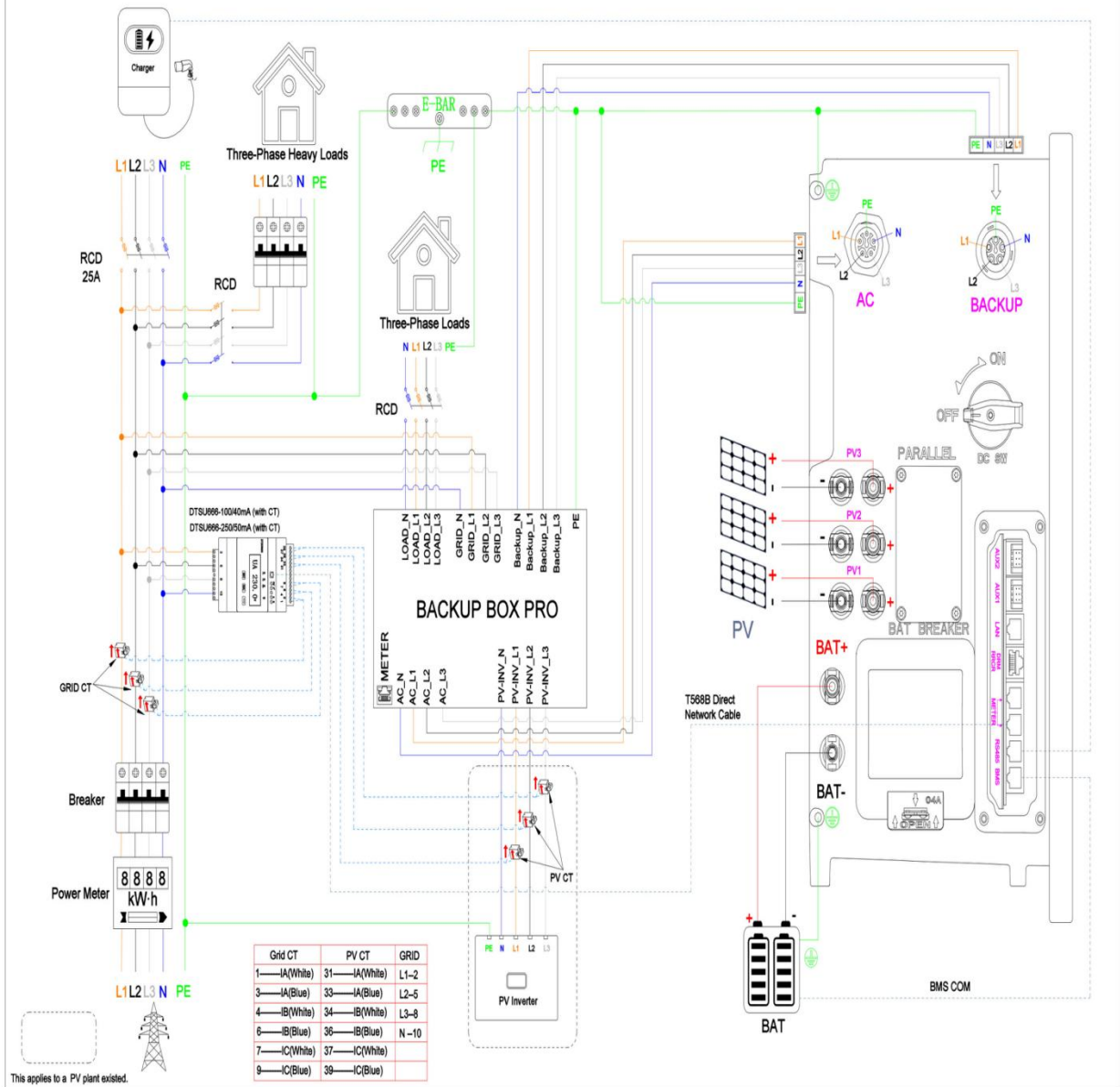



## 09 Manufacturer

---

Name: Bytewatt Technology Co.,Ltd.

Https:// [www.byte-watt.com](https://www.byte-watt.com)

E-Mail: [info@byte-watt.com](mailto:info@byte-watt.com)

Address: No.137,West Shihu Road, Wuzhong District, Suzhou City , Jiangsu Province,  
215000, P.R.China

