

### Eigenschaften

- Monokristalline Solarzellen
- 1 Bypass Diode - minimierter Leistungsabfall bei Beschattung
- Rahmen aus eloxiertem Aluminium
- Speziell gehärtetes ESG-Solarglas
- Äußerst widerstandsfähig
- Ideal für 12V Systeme (Wohnmobile, Boote/ Jachten u.v.m.)

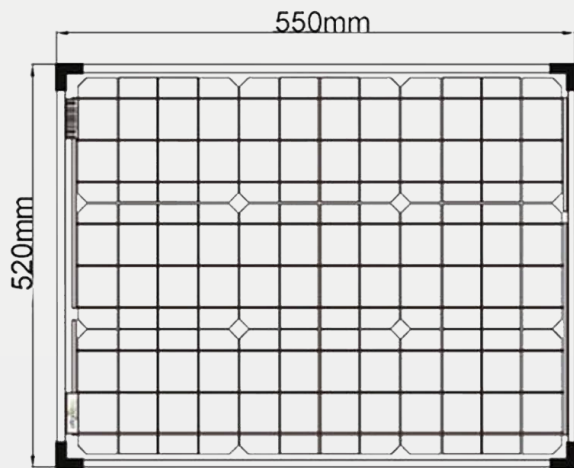

25mm

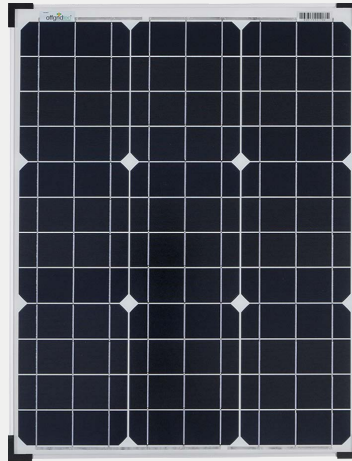
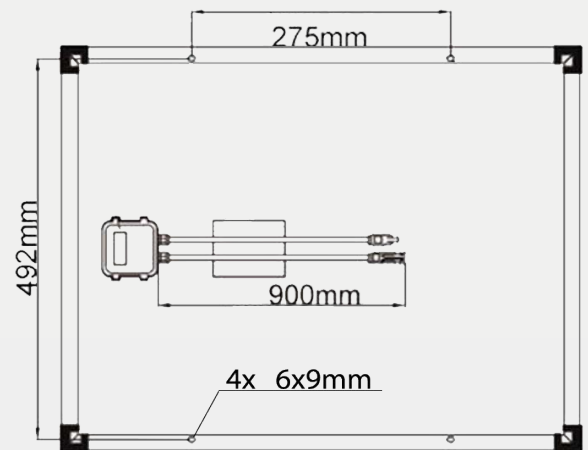

### Offgridtec 50W Mono Solarpanel

Artikelnummer	3-01-001260
EAN	4260297850061
Hersteller-Teilenummer	-001260
Systemspannung	12V / DC
Generatorleistung (Wp)	50 Wp
Modulspannung (Vmp)	20 V
max. Strom (Imp)	2,5 A
Leerlaufspannung (Voc)	24 V
Kurzschlussstrom (Isc)	2,7 A
max. System-Spannung	1000V / DC
Zelltyp	Monokristallin
Umgebungstemperatur	-40°C - +85°C
Toleranz	±3%
Abmessungen (LxBxH)	520 x 550 x 25 mm
Gewicht	3,7 kg
Zell-Wirkungsgrad	>22,3%

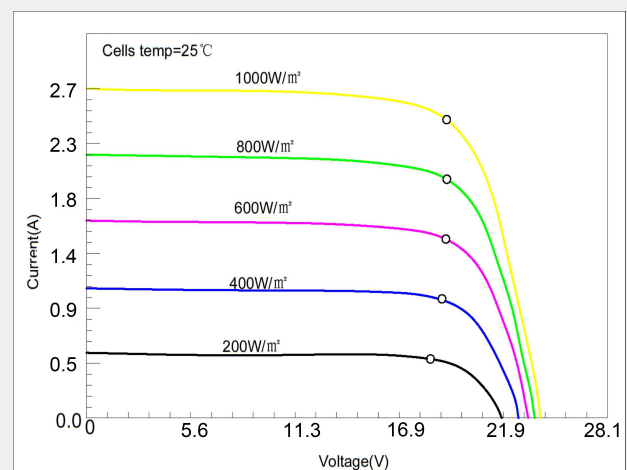

### Characteristics

- Monocrystalline solar cells
- 1 bypass diode - minimised power loss in shaded conditions
- Anodised aluminium frame
- Specially tempered ESG solar glass
- Extremely durable
- Ideal for 12V systems (motorhomes, boats/ yachts etc.)

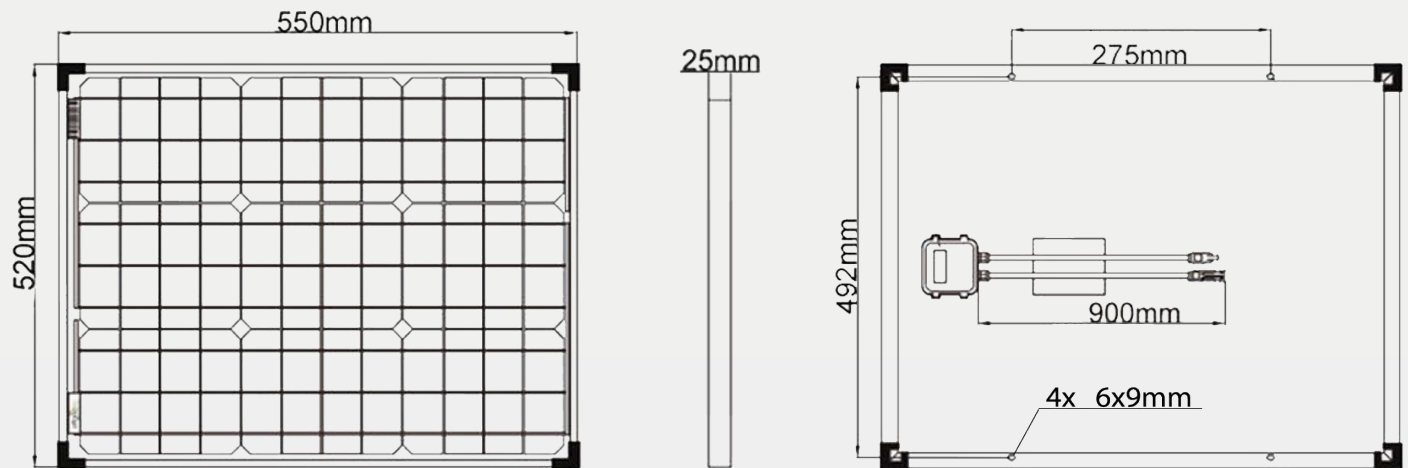
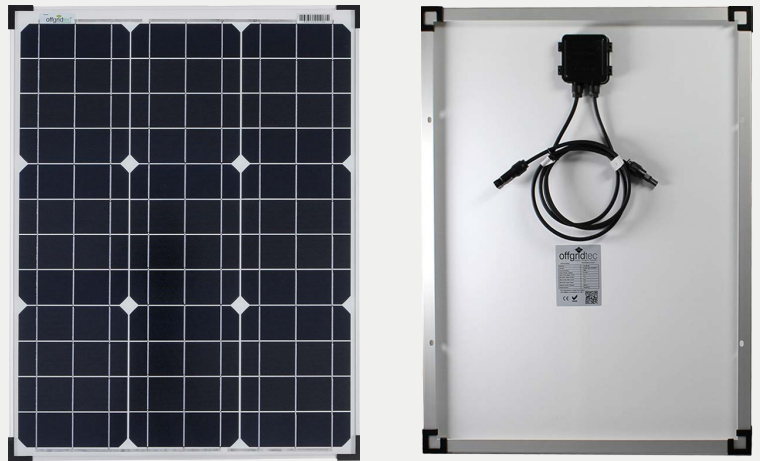

#### Offgridtec 50W MonoSolar panel

Article number	3-01-001260
EAN	4260297850061
Manufacturer part number	-001260
System voltage	12V / DC
Generator output (Wp)	50 Wp
Modulspannung (Vmp)	20 V
max. current (Imp)	2,5 A
Open circuit voltage (Voc)	24 V
Short circuit current (Isc)	2,7 A
Max. system voltage	1000V / DC
Cell type	Monocrystalline
Ambient temperature	-40°C - +85°C
Tolerance	±3%
Dimensions (LxWxH)	520 x 550 x 25 mm
Weight	3,7 kg
Cell efficiency	>22,3%

